

Toward simulation-based construction scheduling using Building Information Models

Part2: Multi-Model

Prof. Dr.-Ing. Raimar Scherer

TU Dresden

Institute of Construction Informatics

Motivation for Multi-Models

Every construction process has a different task that require different application models.

Each application model consists of views from several domain models

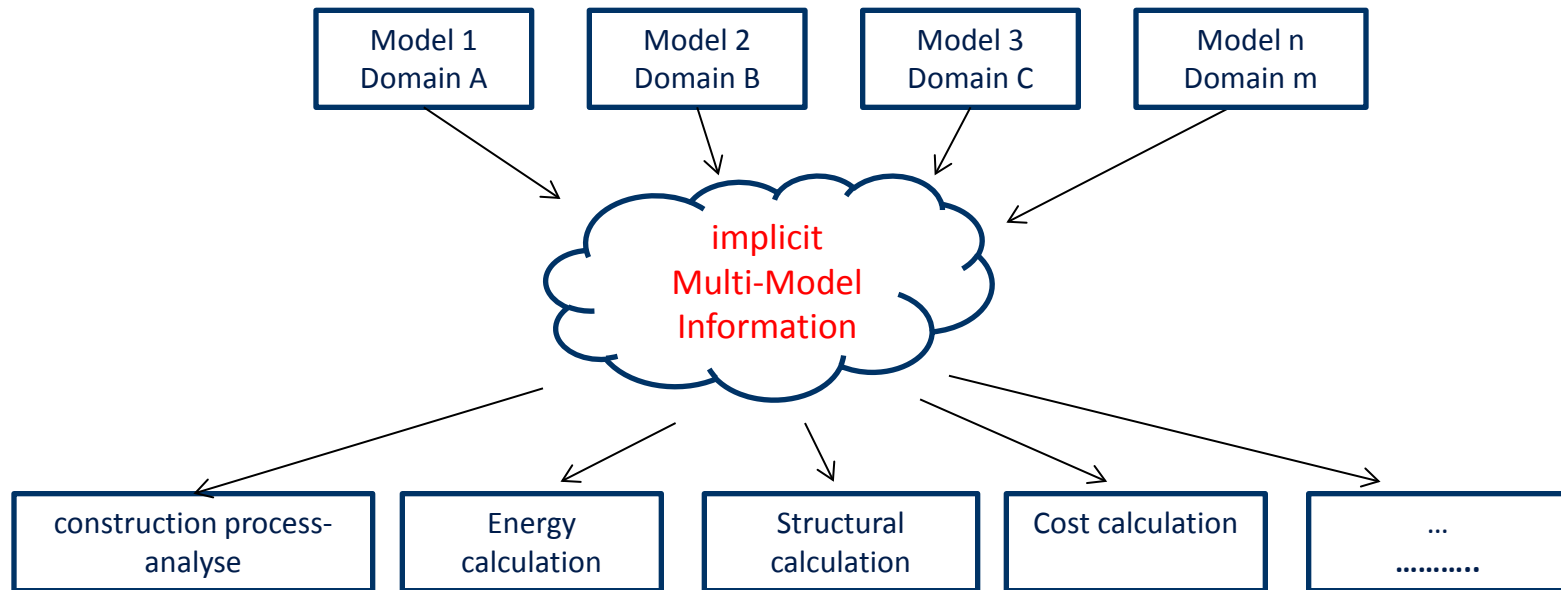

In each application a multi-model is created, but these multi-models can't be exchanged

Structuring of technical information in domain models

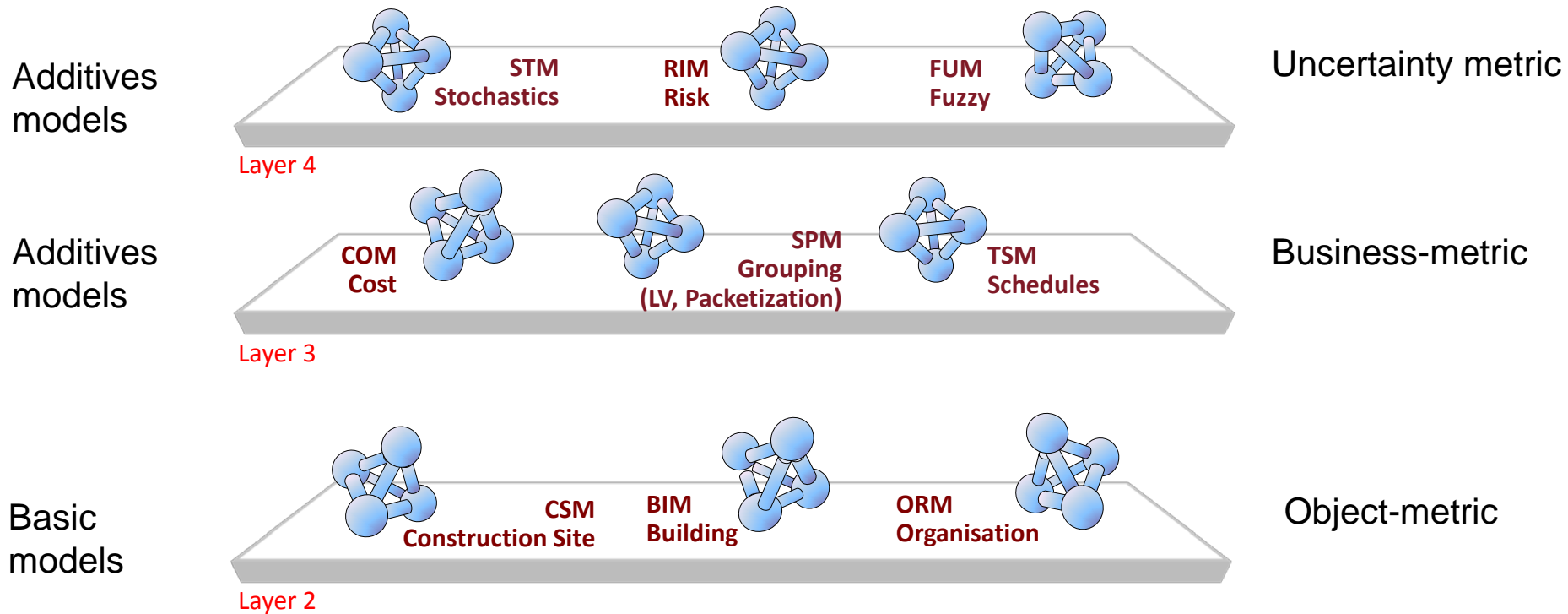

Aactivity

An activity combines information from different specialized models (domain models D_1, \dots, D_n) into a Multi-Model, into an application model

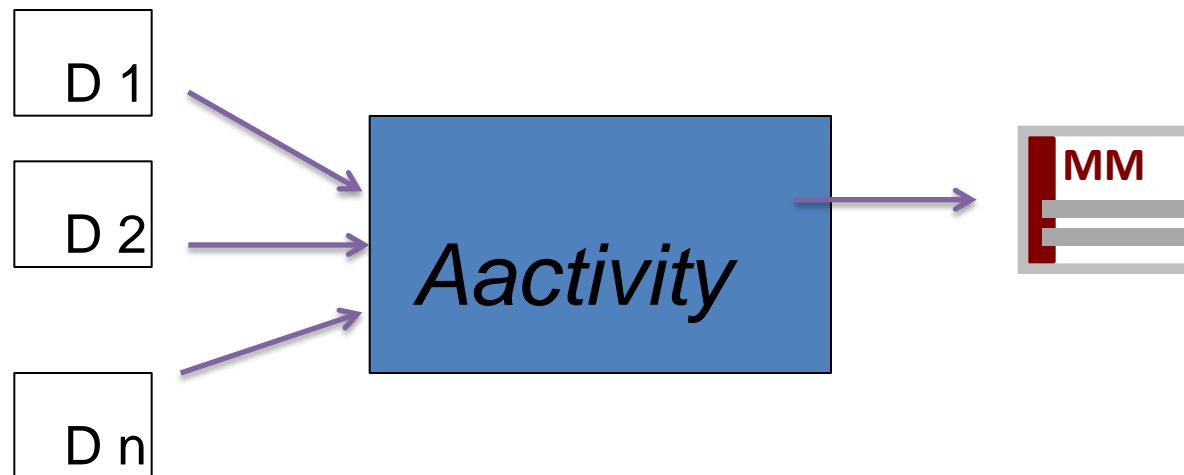

Structuring of technical information in domain models

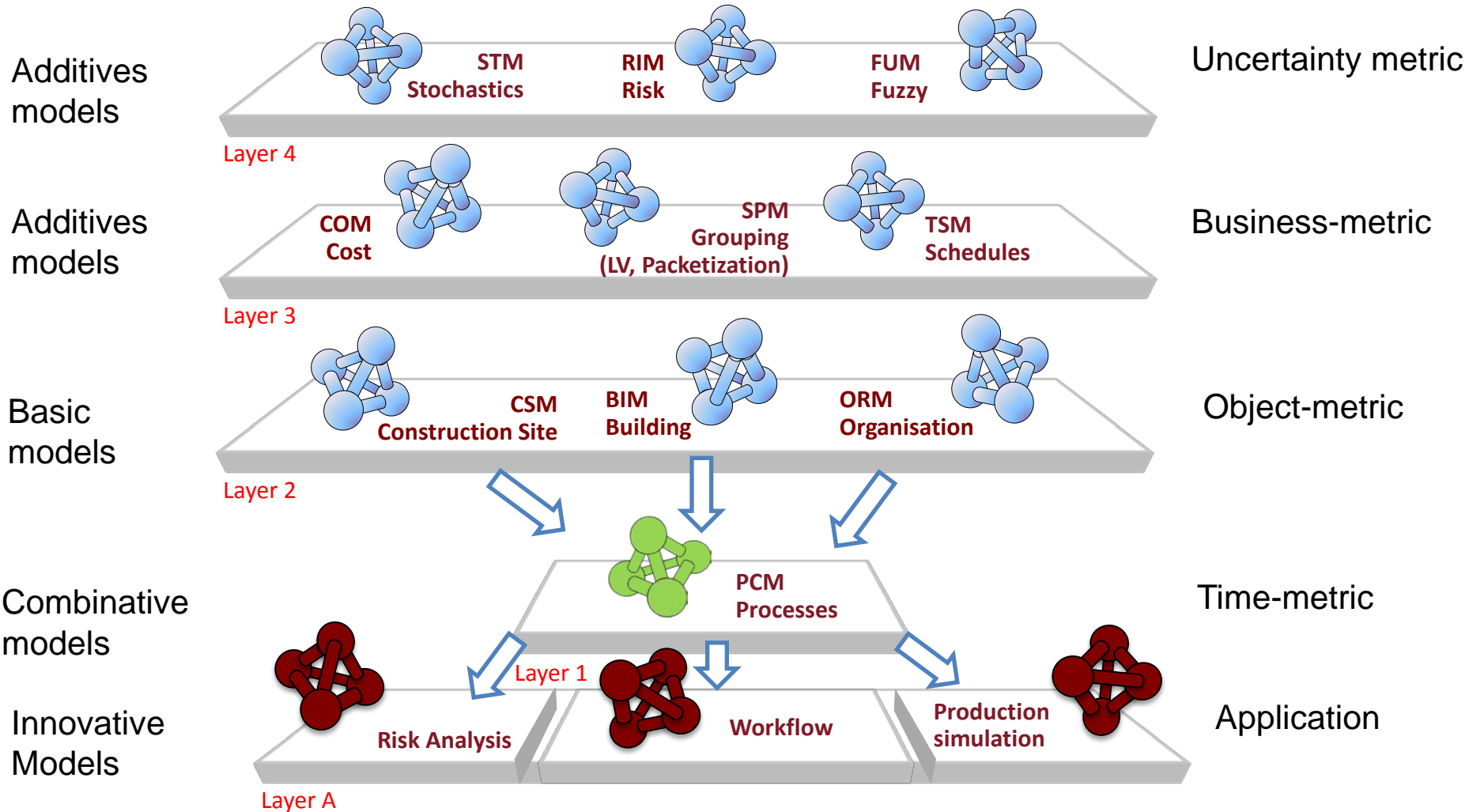

Domain models can be split into partial models (sub-domain models)

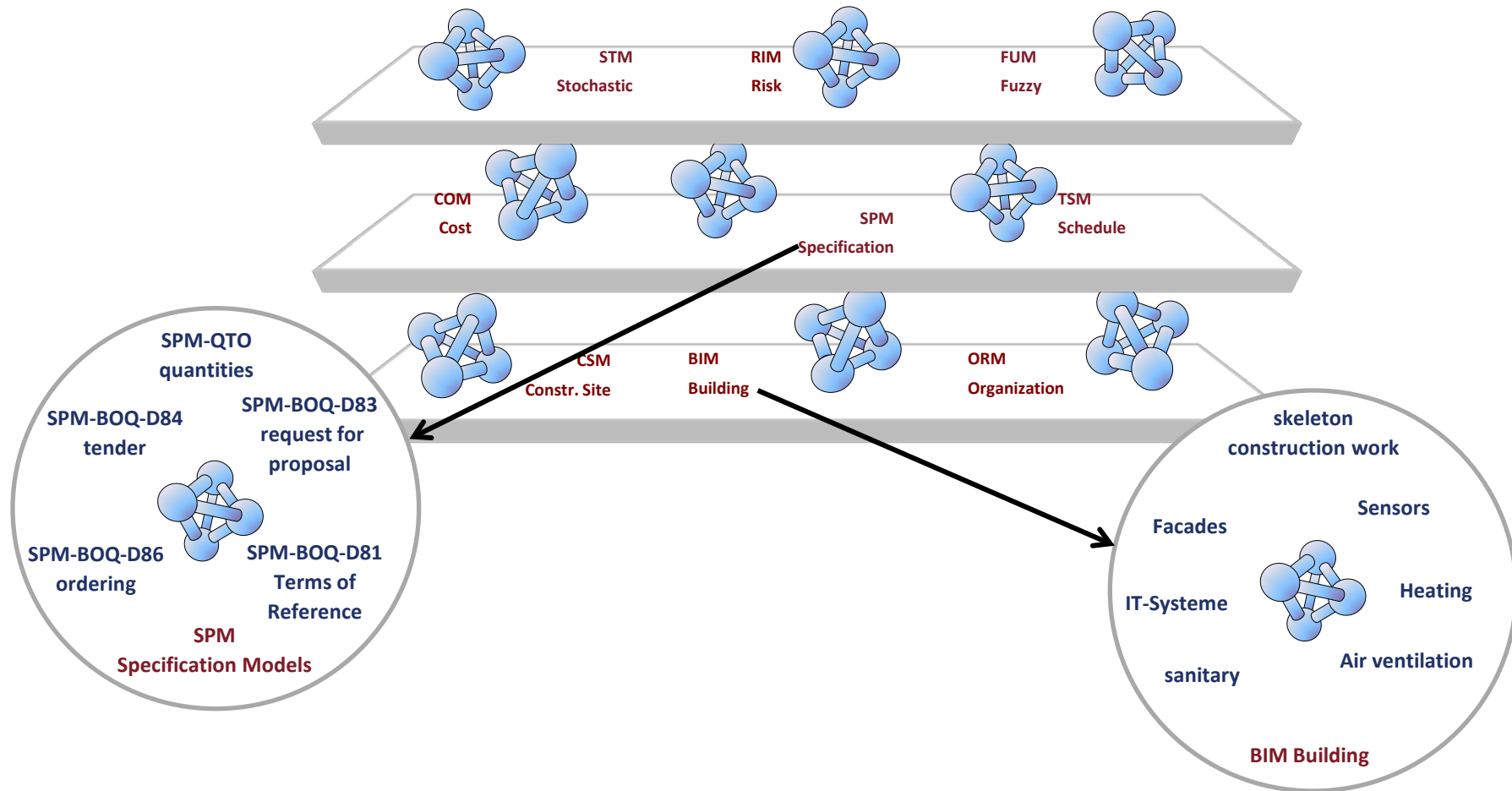

Dimensions of the information space

1. Specialist information => *domain models*
2. Details level=> Accuracy
3. Time-dependent: project phase, context
4. Owner : public, private

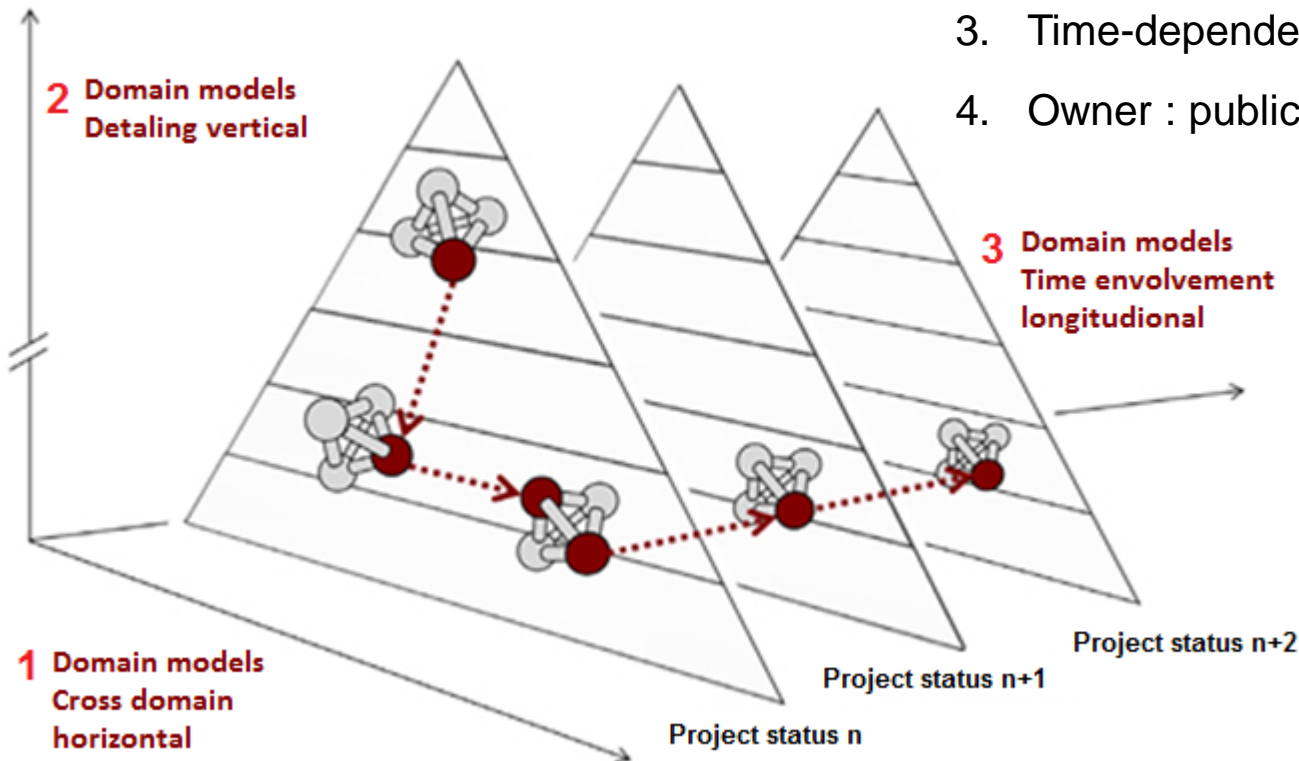

The structure of the multi-model container

Multimodell-Container = several elementary models + link + metadata model

MMC Multi-Model-Container

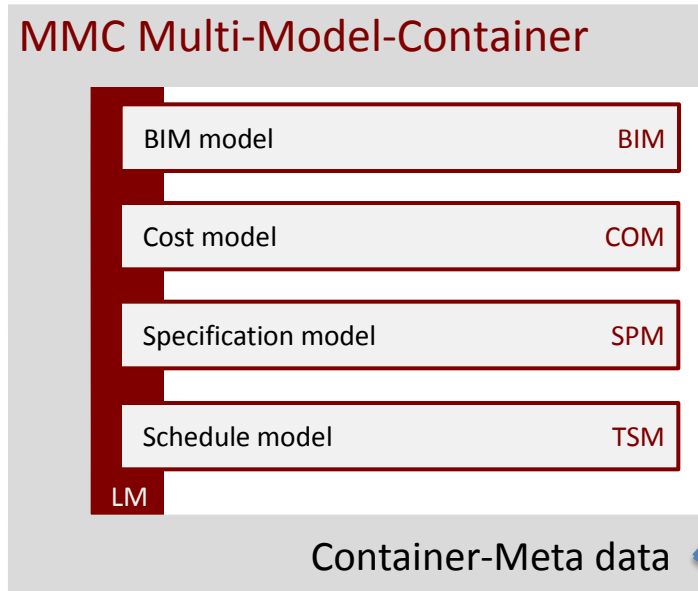

- Task Description up to Partial process description (Phase, domain, ...)
- Process progress (status)
- Process control
- Worker-role
- Further technical details(format, tools, ...)

The structure of the multi-model container

Explicit representation of implicit dependencies. Several separate link models are possible

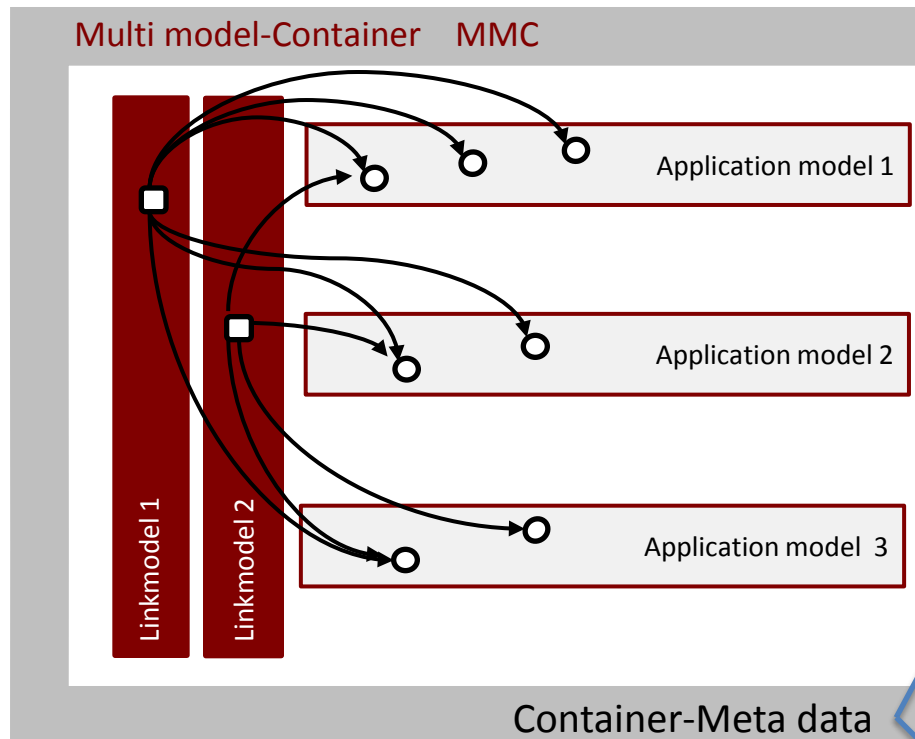

- Task Description up to Partial process description (Phase, domain, ...)
- Process progress (status)
- Process control
- Worker-role
- Further technical details(format, tools, ...)

Cross Domain Links (Horizontal links)

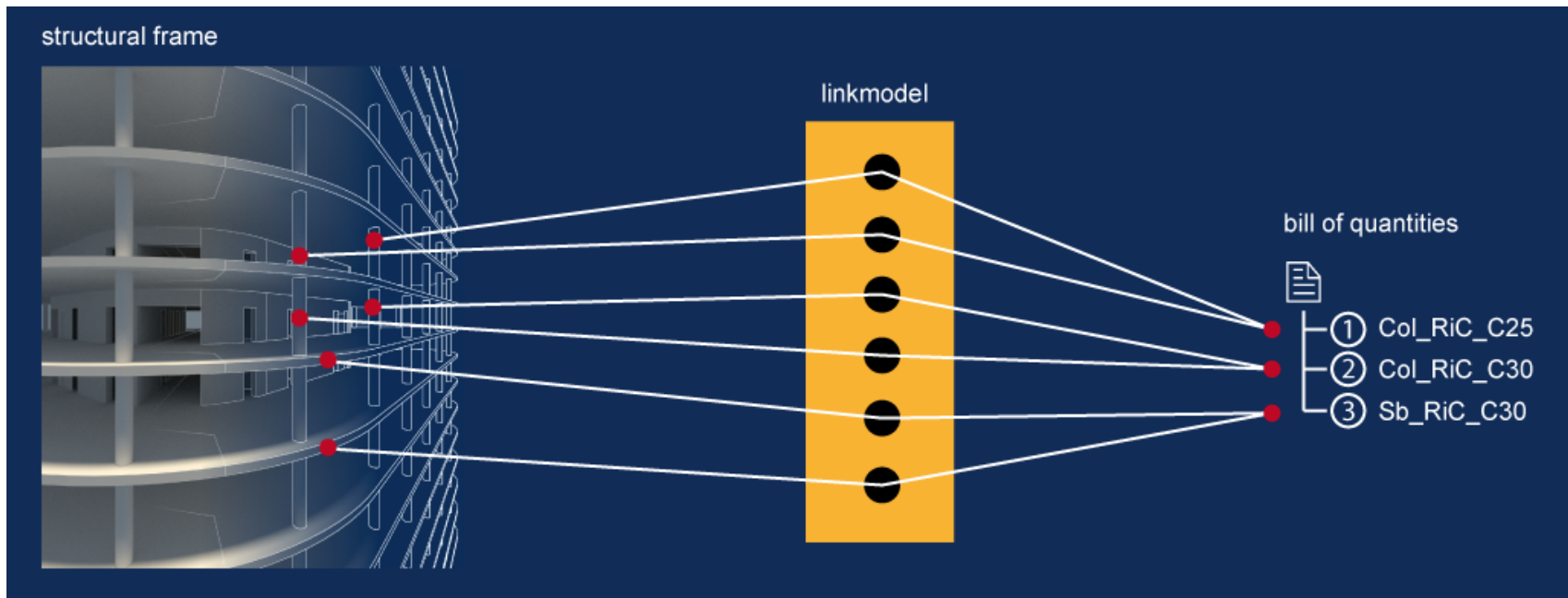

Link-models: Combining heterogeneous information in various specialized models

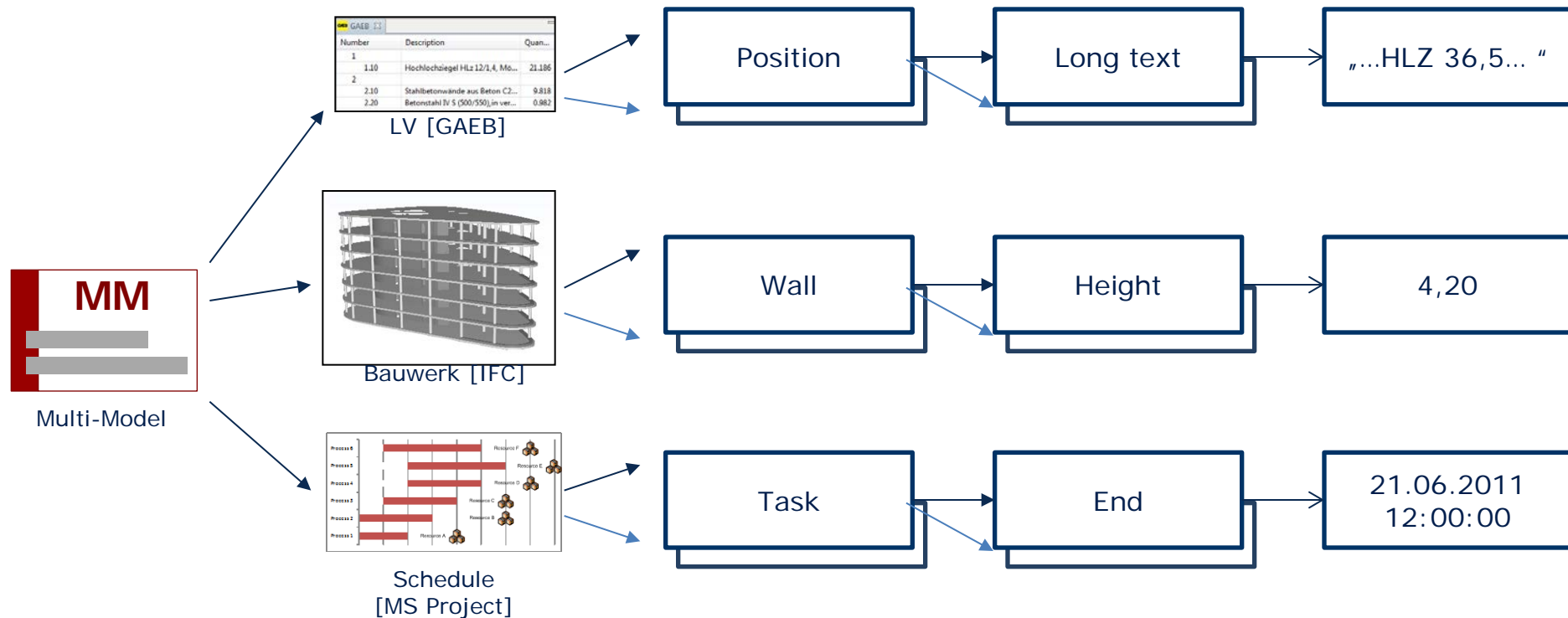

Link-models allow: Answering cross-domain issues

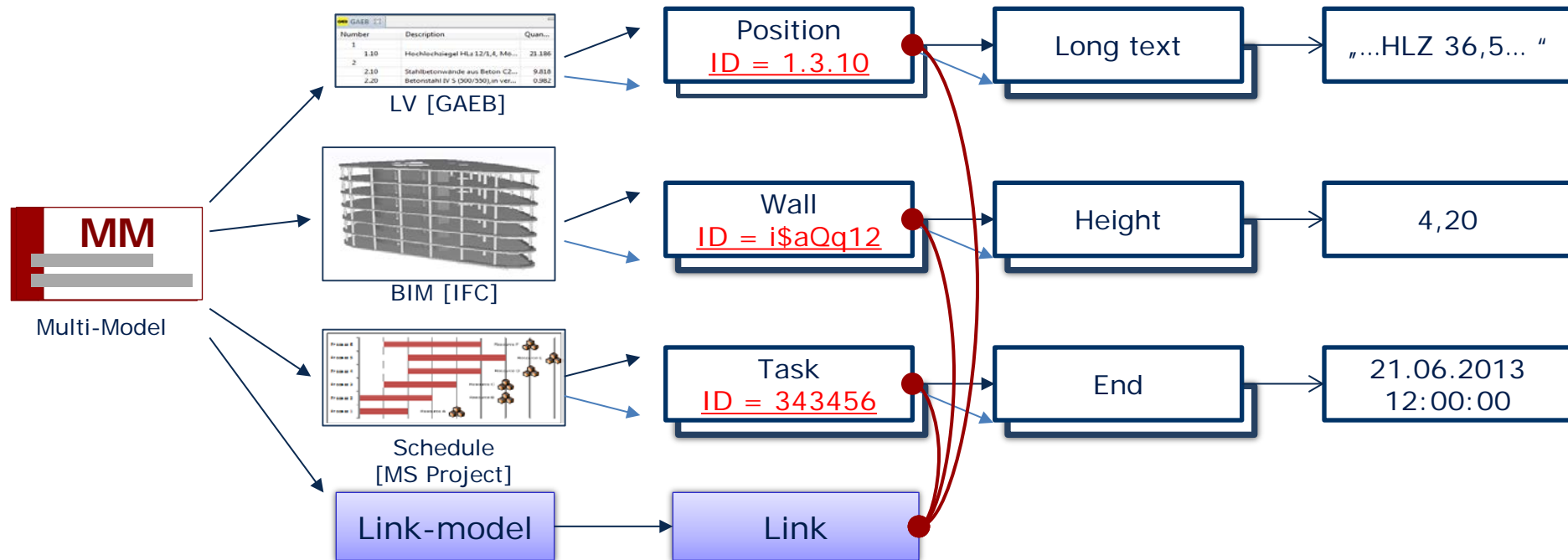

```
SELECT Wall
WHERE position.longtext = "HLZ 36,5"
AND wall.height > 4.00 m
AND Task.end < 28.06.2013)
```



Domain Model Detailing

(Vertikale Links)

space separation: Space Boundary L 1 => L 2 => L 3

1st level

Space connections without
inner boundary

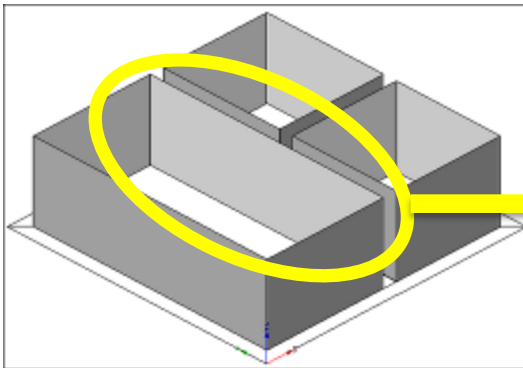

2nd level

Space connections with
inner boundary
(in IFC: Type 2a)

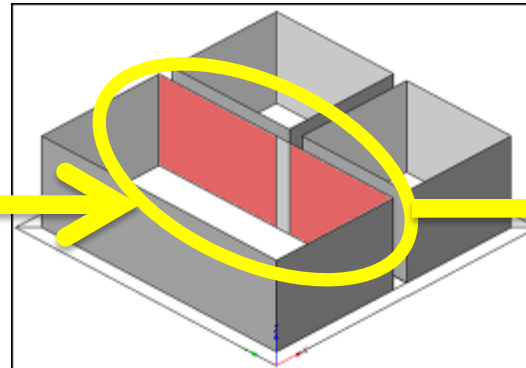

3rd level

2nd level including the
missing wall
(in IFC: Type 2b)

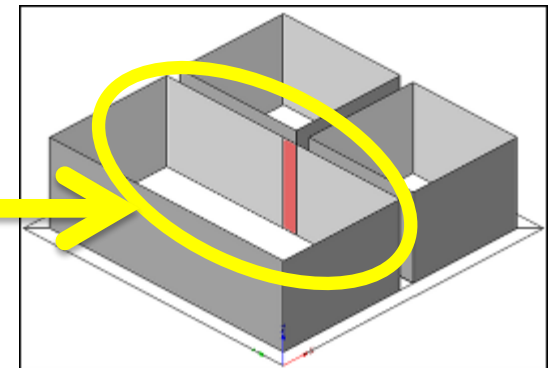

Documents in the container

Linking documents using specialized model elements

M2A2: own „specialized model“
Documents-Container (=Documents-lists)

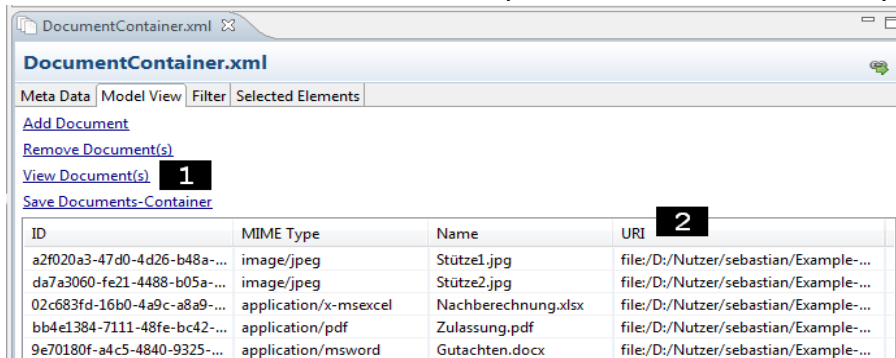

ID	MIME Type	Name	URI
a2f020a3-47d0-4d26-b48a-...	image/jpeg	Stütze1.jpg	file:/D:/Nutzer/sebastian/Example-...
da7a3060-fe21-4488-b05a-...	image/jpeg	Stütze2.jpg	file:/D:/Nutzer/sebastian/Example-...
02c683fd-16b0-4a9c-a8a9-...	application/x-msexcel	Nachberechnung.xlsx	file:/D:/Nutzer/sebastian/Example-...
bb4e1384-7111-48fe-bc42-...	application/pdf	Zulassung.pdf	file:/D:/Nutzer/sebastian/Example-...
9e70180f-a4c5-4840-9325-...	application/msword	Gutachten.docx	file:/D:/Nutzer/sebastian/Example-...

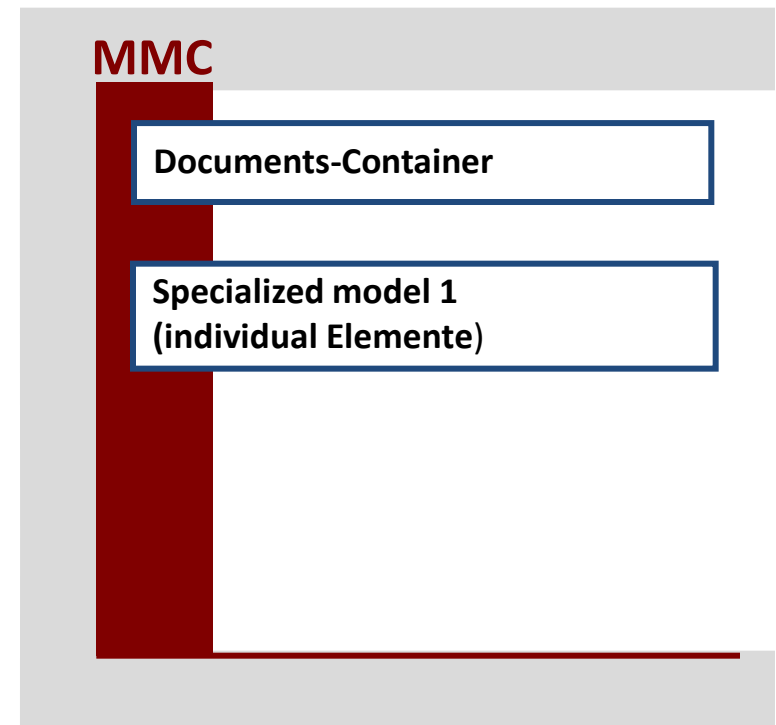

Annotation of application models

Annotation according to six categories

Status s

LoD l

Model

Subject m

Project phase p

Domain model d

Data format f

Start with Multi-Model-Templates

Definition through multimodell-templates

Each domain model is described by its annotation.

Domain models can be empty.

Meta data contains the task description.

